



**YOU DESERVE A BIG SMILE**



**SOLVO IMPLANTS**

BRITISH QUALITY

**2025 CATALOG**



SOLVO Dental Implants Company is a well established, technologically innovative British company. Implementing the knowledge and experience derived from our R&D team, SOLVO can offer dental implant solutions to meet the needs of today highly demanding dental restoration field.

SOLVO Implants manufactures and supplies a comprehensive range of implants with state of the art SLA surface treatment.



SOLVO Implants continuously strives to design, develop and manufacture implants and prosthetics of the highest quality by implementing the latest advancement in implant science.

SOLVO Implants market a comprehensive range of dental implants and superstructures.





SOLVO Implants surface treatment is carried out by one of the worlds leading laboratories who have over ten years experience and have produced thousands of implants with a high level of success. SOLVO Implants maintain a meticulous quality control system and complies with major quality control standards.

The implants, prosthetics and accompanying aids manufactured by SOLVO Implants, naturally integrate into the body, reduce healing time, minimize rejections, prevent complications and provide durability for years. The surface of all SOLVO's implants undergo a complex procedure which significantly increases the success of the osseointegration process.



The SOLVO Implants consulting team offers all-round professional and technical support. SOLVO Implants continuously strives to improve its products and simplify your procedures, providing the patients with reliable long-lasting successful results.

\*All specifications in this catalog are subject to change without prior notice. All models shown are for simulation purposes.



## SOLVO<sup>®</sup> SLA Surface Treatment

# SOLVO Implant Surface & Osseointegration

**SOLVO SLA Surface** provides faster bone recovery and immediate loading success rate.

**SOLVO SLA** complex surface design with significant surface enlargement enhances the procedure and provides:

- Increased primary stability with reduced healing time
- Active support of bone attachment
- Higher wettability with blood/high affinity for blood
- Early loading / immediately loading
- Higher osteoconductivity of the surface



**SOLVO<sup>®</sup>**



**LIFE TIME GUARANTEE**  
**SOLVO IMPLANT SYSTEM**

**SOLVO<sup>®</sup> IMPLANTS HAVE LIFE TIME WARRANTY**

# SOLVO® SLA Surface Treatment

**SOLVO Implants** focused its research on the factor of surface roughness and we used various techniques in order to compare our results with the best, universally recognized implant manufacturers. The following results were obtained through metallographic implant surface cross-section analysis in two locations: the base and at the end of the implant. The analysis accurately determined the depth and width of the dimples, as well as their geometry which is clearly visible on the image bellow. The surface is well-developed with large and small dimples which enhance osseointegration.

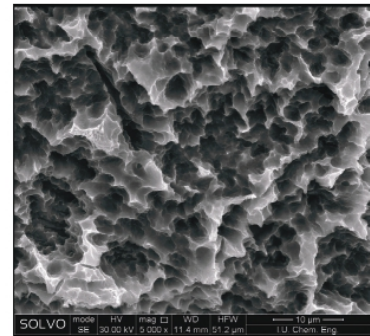
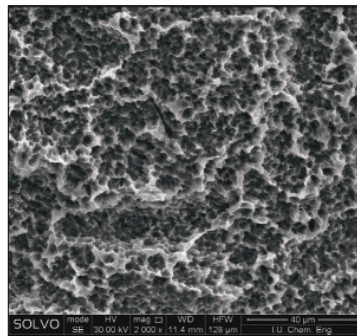
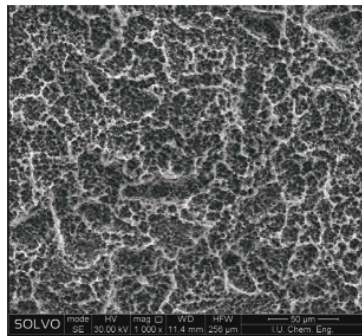
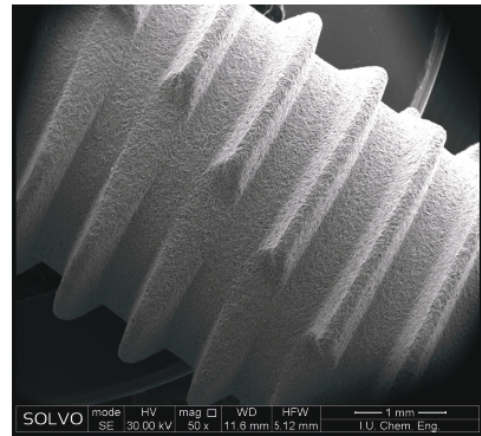

**SOLVO®** SLA surface treatment introduces much improved osseointegration by penetrating all of the pores and providing a strong bone anchoring to the surface (high Bone -to implant contact - BIC).

## Advantages

- Optimal roughness characteristics
- Proven long-term solution
- High primary stability
- Rapid bone ongrowth
- Reduce healing time
- Early implant loading

## Quality and Performance Tests

**SOLVO®** SLA Surface stimulates active bone tissue growth throughout entire implant surface resulting in rapid bone growth. the increased surface area provides perfect bone-implant connection. Due to this advantage the implant has higher primary stability and quick osseointegration. It can be used with one or two stage protocol.

**SOLVO Implants** periodically performs various quality assurance tests.



## SOLVO SLA SURFACE®

# SOLVO Implant Surface & Osseointegration

SOLVO Implants Surface is the latest generation of dental implant surfaces. SOLVO Implant System provides an ideal tight connection between the implant and abutment.

Researches show that SLA Surface stimulates bone tissue growth throughout entire implant surface, which provides high mechanical stability and osseointegration in much shorter terms.

These unique properties of the surface allow performing rehabilitation at an earlier stage as well as significantly reduce the risk within implant installation under one stage protocol.

Several implant-related factors such as implant surface topography, and surface roughness influence osseointegration. Titanium implants with adequate roughness influence the primary stability of implants, enhance bone-to-implant contact, and increase removal torque force.

The surface roughness of the implants can significantly alter the process of osseointegration because the cells react differently to smooth and rough surfaces: osteoblastic proliferation and collagen synthesis are increased on rough surfaces.

SOLVO Implants focused its research on the factor of surface roughness and we used various techniques in order to compare our results with the best, universally recognized implant manufacturers.



## SOLVO SLA Surface Advantages

### Rapid Osseointegration

The implant's initial stability is generated by the mechanical locking of the screws themselves regardless of surface features. Surface qualities are very important for maintaining mechanical stability, mainly for the soft bone and for immediate loading. The biological factors determine and retain implant stability, so that the implant surface supports the bone's biological healing process. SOLVO SLA Surface induces osseogenesis on the surface, thus accelerating and strengthening osseointegration, as compared to a machined surface.

### Osseconductivity

The SOLVO SLA Surface layer enables bone growth directly on the surface, whereas the bone in the machined option only undergoes apposition from the osteotomic region. Histological tests showed that the bone responds faster to SOLVO SLA Surface where osseogenesis follows the screw outline in the initial healing stages => higher BIC, earlier.

### Maintaining the implant's mechanical stability

During Week 1 of post implantation healing, the mechanical relaxation of the bone and the remodeling around the implant might impair implant stability and risk its success, mainly in areas of soft bone under heavy occlusal loading. The quick and strong osseointegration achieved with SOLVO SLA Surface maintains mechanical stability during healing.

**Contemporary  
Hybrid Design**

**Biocompatible &  
Osseoconductive**

**SOLVO SLA SURFACE ADVANTAGES**

- High Primary Stability
- Minimally Invasive Switching
- Built-in Platform Switching
- Increases Optimal Osseointegration
- Faster Healing Process

# SOLVO IMPLANT DESIGN

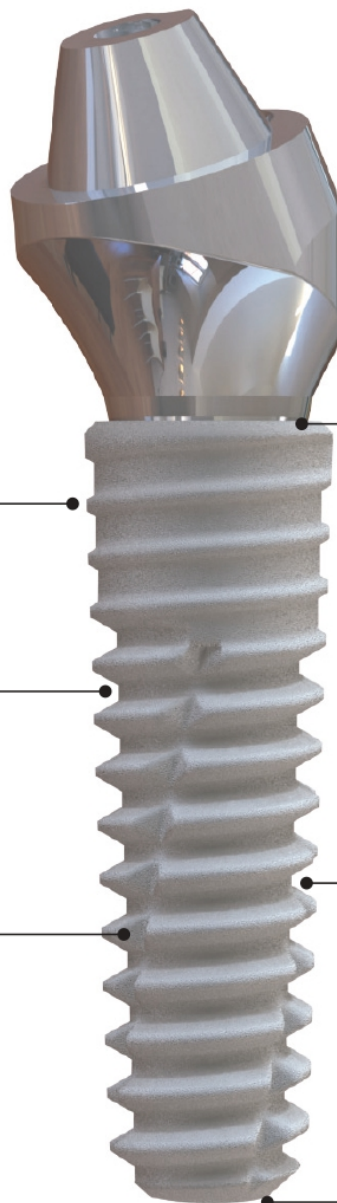

**Single Pitch Thread**

- 0,9 pitch x 0,25 depth x double lead
- Synchronized thread
- Optimized design for Special Surface
- Reinforce fixture strength

**Corkscrew Thread**

- Aggressive self threading design
- Lower sensitivity to drill size
- Maintains implant path

**Helix Cutting Edge**

- Powerful self threading
- Change path easily

**Built-in Platform Switching**

- Self-sealing 11° Morse taper joins the abutment to the implant
- Hermetic seal minimizes micro movement reducing percolation of saliva & bacteria
- Abutment keeps the interface away from the bone.

**Open Thread**

- Protect Bone Necrosis

**Apical Design**

- Self Tapping
- Ability for path change
- Secure initial stability

## SOLVO IMPLANT DESIGN

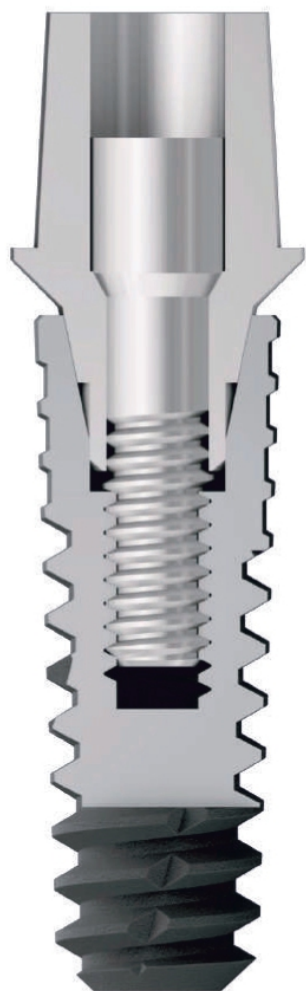
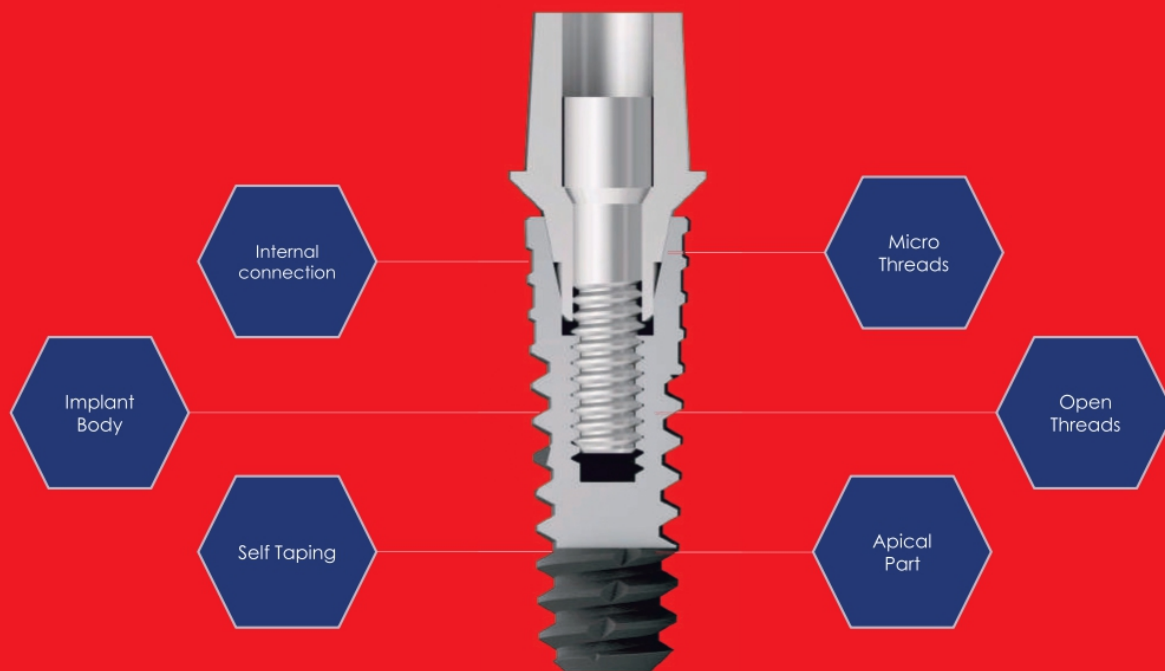

### Unique Clinical Benefits:

- Perfect Esthetics
- Easily stabled and controlled during placement
- Greater initial placement stability.
- Unique self-drilling capabilities with a redirection ability of the implant during replacement
- Penetration to small diameters
- Minimal Pressure on Hard Bone
- Self-condensing & Self-directing in line of insertion.
- High Bone Condensation properties leading to high initial stability
- Long-term Stability

**Material:** Titanium - Ti-6Al-4V ELI

**Treatment:** SOLVO SLA Surface

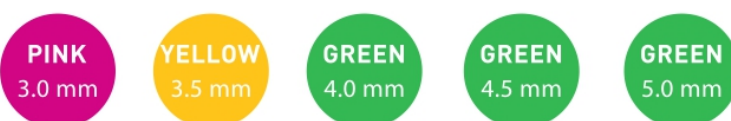



Premium Ultra Mini Implant

Ø  
3.0



Surface	L-10mm	L-11.5mm	L-13mm	L-15mm
SLA	SLV13010UM	SLV13011UM	SLV13013UM	SLV13015UM
SOLVO Act	SLV13010UMAct	SLV13011UMAct	SLV13013UMAct	SLV13015UMAct

Ø3.0	Model	
	SLA	SLV Act
L		
10	SLV13010UM	SLV13010UMAct
11.5	SLV13011UM	SLV13011UMAct
13	SLV13013UM	SLV13013UMAct
15	SLV13015UM	SLV13015UMAct

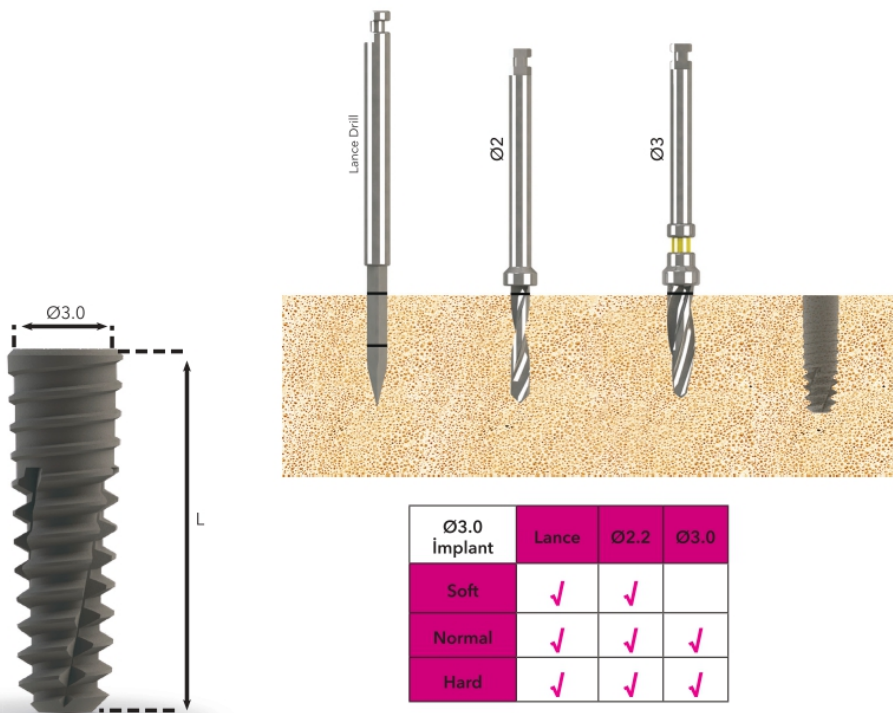

Ø3.0 Implant	Lance	Ø2.2	Ø3.0
Soft	✓	✓	
Normal	✓	✓	✓
Hard	✓	✓	✓

# SOLVO IMPLANTS

# DIMENSIONS

## Premium Mini Implant

Ø  
3.5



Surface	L-8.5mm	L-10mm	L-11.5mm	L-13mm	L-15mm
SLA	SLV13585M	SOL13510M	SLV13511M	SLV13513M	SLV13515M
SOLVO Act	SLV13585MAct	SOL13510MAct	SLV13511MAct	SLV13513MAct	SLV13515MAct

Ø3.5	Model	
L	SLA	SLV Act
8.5	SLV13585M	SLV13585MAct
10	SLV13510M	SLV13510MAct
11.5	SLV13511M	SLV13511MAct
13	SLV13513M	SLV13513MAct
15	SLV13515M	SLV13515MAct

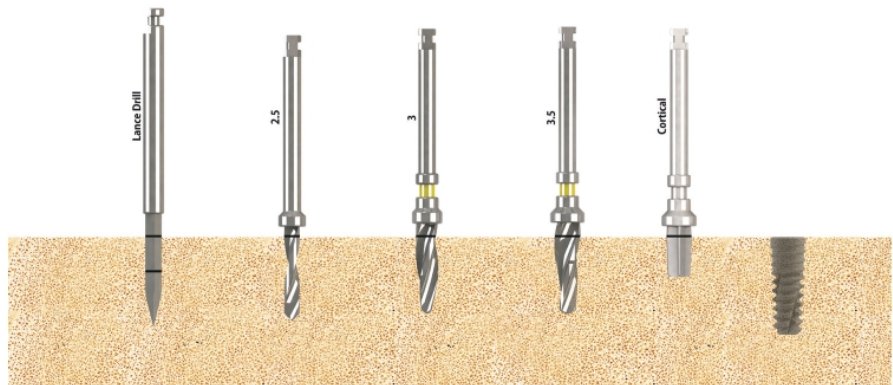
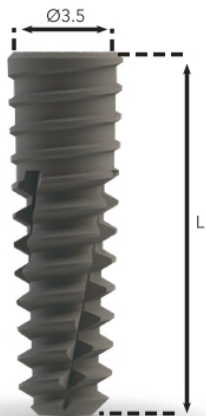

Ø3.5 Implant	Lance Drill	Ø2.2 Drill	Ø3.0 Drill	Ø3.5 Drill	Ø3.5 Cortical
Soft	✓	✓	✓		
Normal	✓	✓	✓	✓	
Hard	✓	✓	✓	✓	✓

## Premium Implant

Ø  
4.0

w. Standard Connection



Surface	L-7mm	L-8.5mm	L-10mm	L-11.5mm	L-13mm	L-15mm
SLA	SLV14070S	SLV14085S	SLV14010S	SLV14011S	SLV14013S	SLV14015S
SOLVO Act	SLV14070SAct	SLV14085SAct	SLV14010SAct	SLV14011SAct	SLV14013SAct	SLV14015SAct

Ø4.0	Model	
L	SLA	SLV Act
7	SLV14070S	SLV14070SAct
8.5	SLV14085S	SLV14085SAct
10	SLV14010S	SLV14010SAct
11.5	SLV14011S	SLV14011SAct
13	SLV14013S	SLV14013SAct
15	SLV14015S	SLV14015SAct

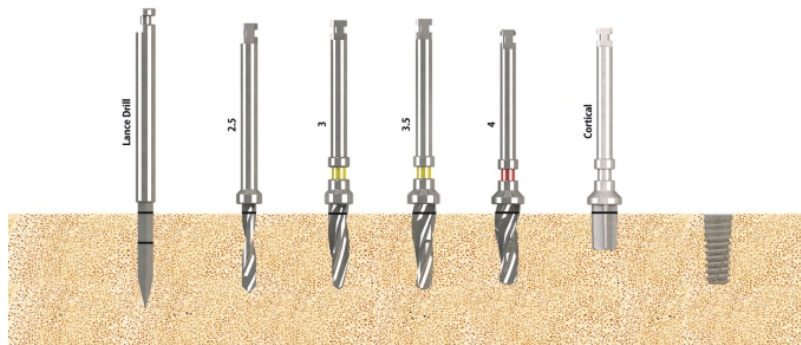
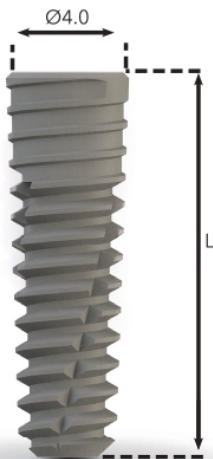

Ø4.0 Implant	Lance Drill	Ø2.2 Drill	Ø3.0 Drill	Ø3.5 Drill	Ø4.0 Drill	Ø4.0 Cortical
Soft	✓	✓	✓		✓	
Normal	✓	✓	✓	✓	✓	
Hard	✓	✓	✓	✓	✓	✓

# SOLVO IMPLANTS

# DIMENSIONS

## Premium Implant

Ø  
4.5

w. Standard Connection



Surface	L-7mm	L-8.5mm	L-10mm	L-11.5mm	L-13mm	L-15mm
SLA	SLV14570S	SLV14585S	SLV14510S	SLV14511S	SLV14513S	SLV14515S
SOLVO Act	SLV14570SAct	SLV14585SAct	SLV14510SAct	SLV14511SAct	SLV14513SAct	SLV14515SAct

Ø4.5	Model		
	L	SLA	SLV Act
	7	SLV14570S	SLV14570SAct
	8.5	SLV14585S	SLV14585SAct
	10	SLV14510S	SLV14510SAct
	11.5	SLV14511S	SLV14511SAct
	13	SLV14513S	SLV14513SAct
	15	SLV14515S	SLV14515SAct

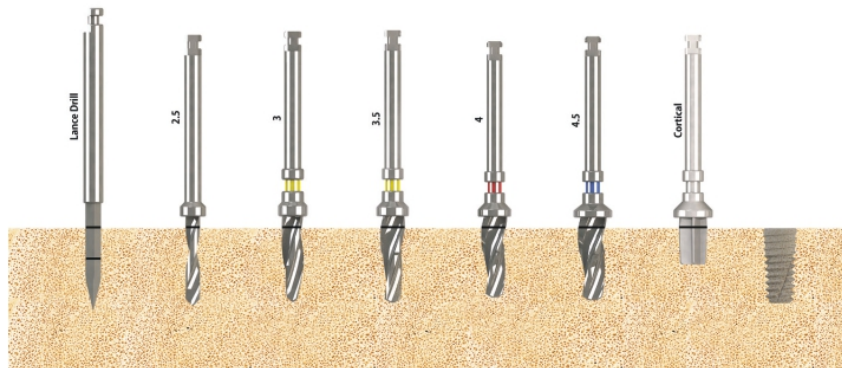

Ø4.5 implant	Lance Drill	Ø2.2 Drill	Ø3.0 Drill	Ø3.5 Drill	Ø4.0 Drill	Ø4.5 Drill	Ø4.5 Cortical
Soft	✓	✓	✓	✓	✓		
Normal	✓	✓	✓	✓	✓	✓	
Hard	✓	✓	✓	✓	✓	✓	✓



# ABUTMENTS

# DIMENSIONS

## Healing Abutment



Ultra Mini			
<b>GH</b>	1.0	2.0	3.0
<b>H</b>	3.0	5.0	7.0
<b>Ø3.0</b>	SLV2HLA3013UM	SLV2HLA3025UM	SLV2HLA3037UM

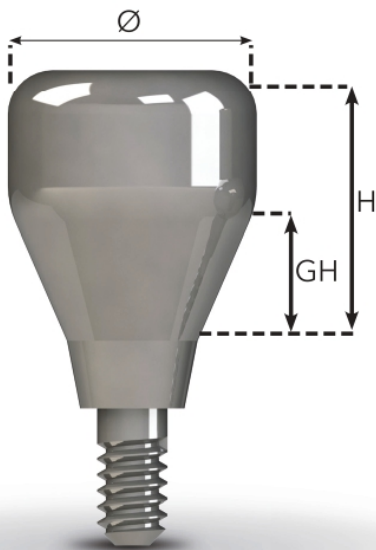

Mini			
<b>GH</b>	1.0	2.0	3.0
<b>H</b>	3.0	5.0	7.0
<b>Ø4.5</b>	SLV1HLA4513M	SLV1HLA4525M	SLV1HLA4537M
<b>Ø5.5</b>	SLV1HLA5513M	SLV1HLA5536M (GH:3.0, H:6.0)	

Standard			
<b>GH</b>	1.0	2.0	3.0
<b>H</b>	3.0	5.0	7.0
<b>Ø4.5</b>	SLV1HLA4513S	SLV1HLA4525S	SLV1HLA4537S
<b>Ø5.5</b>	SLV1HLA5513S	SLV1HLA5525S	SLV1HLA5537S

## Straight Abutment

- Used for making general cement-type prosthesis.
- 11° taper connection enhances safety
- Cross section design prevents prosthetic restoration
- Use the 1,2 Hex Driver
- Tightening torque: Standard 30 Ncm, Mini 20Ncm, Ultra Mini 15 Ncm
- Includes abutment screw

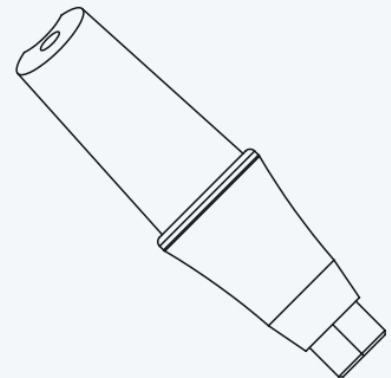

## Angled Abutment

- Used for the path adjustment of prosthesis at 15° - 25° axial angle
- 11° taper connection for excellent safety
- Functions as a double hex type (X and Y hex types)
- Use the 1,2 Hex Driver
- Tightening torque: Standard 30 Ncm, Mini 20Ncm, Ultra Mini 15 Ncm
- Includes abutment screw

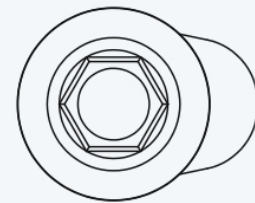

## Equator Abutment

- Used for making implant retained over dentures
- Accommodates up to 40° divergence between two implants
- Use the Locator Torque Driver
- Tightening torque: 30 Ncm

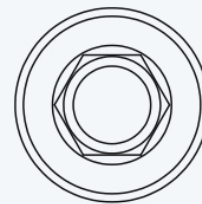

## Ball Abutment

- Used for stud-type over dentures
- Use the 1,2 Hex Driver
- Tightening torque: Standard 25 Ncm, Mini 20 Ncm, Ultra Mini 15 Ncm

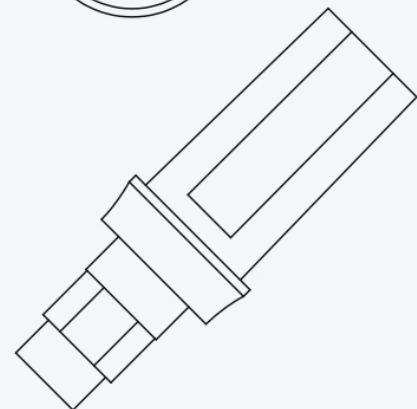

## Multi-Unit Straight Abutment

- Used with esthetic low cylinders and components
- Connected to implant by multi-angled abutment carrier
- Tightening torque: Standard 30 Ncm, Mini 20 Ncm
- (Plastics or temporary coping screw torque: 15 Ncm)

## Multi-Unit Angled Abutment

- Used with aesthetic low cylinders and components
- Connected to implant by multi-angled abutment carrier
- Includes multi-angled abutment screw
- Multi-angled carrier sold separately
- Tightening torque: Standard 30 Ncm, Mini 20 Ncm
- (Plastics or temporary abutment screw torque: 15 Ncm)

## Threaded Abutment

- Used with aesthetic low cylinders and components
- Tightening torque: Standard 25 Ncm, Mini 20 Ncm, Ultra Mini 15 Ncm

## Ucla Abutment

- Use for cases with path and aesthetic and spatial constraints
- After customization, dental alloy (gold, non-precious metal) is used for casting
- Use a 1.2 hex driver
- Packing unit : Abutment + Ti screw
- Tightening torque : Standard 30 Ncm, Mini 20 Ncm - Used for cases with path

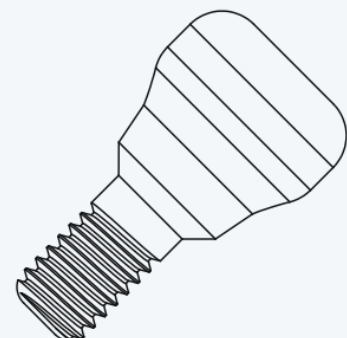
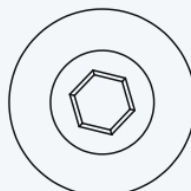
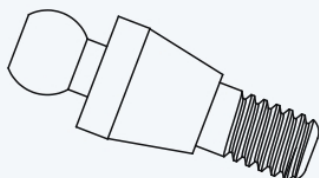

DIMENSIONS

ABUTMENTS

∅  
3.0

Ultra Mini Straight Abutment

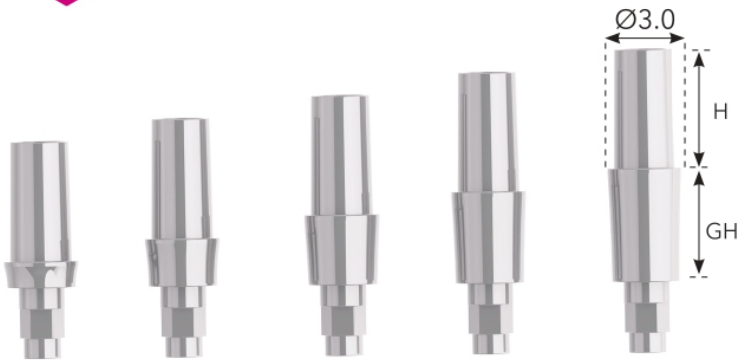

H	GH	∅3.0
5.5	1.0	SLV2SA30155UM
	2.0	SLV2SA30255UM
	3.0	SLV2SA30355UM
	4.0	SLV2SA30455UM
	5.0	SLV2SA30555UM

∅  
4.5

Mini Straight Abutment



H	GH	∅4.5
5.5	1.0	SLV1SA45155M
	2.0	SLV1SA45255M
	3.0	SLV1SA45355M
	4.0	SLV1SA45455M
	5.0	SLV1SA45555M

∅  
5.0

Mini Straight Abutment



H	GH	∅5.0
5.5	1.0	SLV1SA50155M
	2.0	SLV1SA50255M
	3.0	SLV1SA50355M
	4.0	SLV1SA50455M
	5.0	SLV1SA50555M



# ABUTMENTS

# DIMENSIONS

## Standard Straight Abutment

4.5



H	GH	Ø4.5
5.5	1.0	SLV1SA45155S
	2.0	SLV1SA45255S
	3.0	SLV1SA45355S
	4.0	SLV1SA45455S
	5.0	SLV1SA45555S

## Standard Straight Abutment

5.0

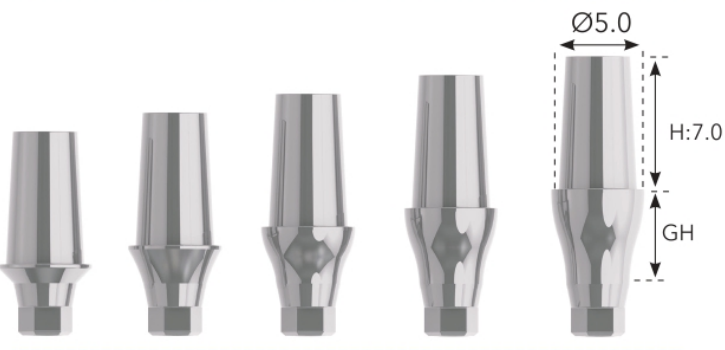
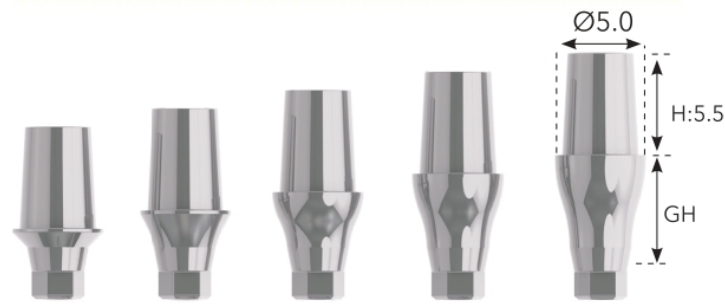

H	GH	Ø5.0
4.0	1.0	SLV1SA50140S
	2.0	SLV1SA50240S
	3.0	SLV1SA50340S
	4.0	SLV1SA50440S
	5.0	SLV1SA50540S
5.5	1.0	SLV1SA50155S
	2.0	SLV1SA50255S
	3.0	SLV1SA50355S
	4.0	SLV1SA50455S
	5.0	SLV1SA50555S
7.0	1.0	SLV1SA50170S
	2.0	SLV1SA50270S
	3.0	SLV1SA50370S
	4.0	SLV1SA50470S
	5.0	SLV1SA50570S

# DIMENSIONS

# ANGLED ABUTMENTS

3.0

## Ultra Mini Angled Abutment

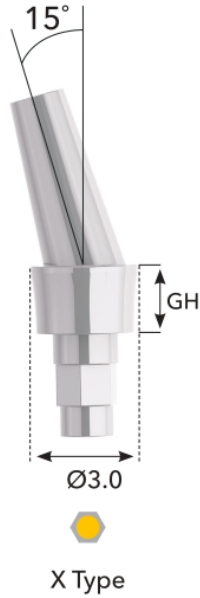

GH	Type - Angle	Ø3.0
2.0	X Type - 15°	SLV2ANA30215XUM

4.3

## Mini Angled Abutment

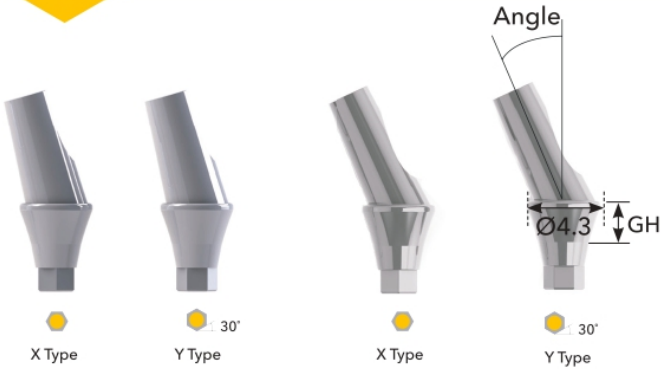

GH	Type	Angle	Ø4.3
2.0	X Type	15°	SLV1ANA43215XM
	Y Type	15°	SLV1ANA43215YM
	X Type	25°	SLV1ANA43225XM
	Y Type	25°	SLV1ANA43225YM



GH	Type	Angle	Ø4.3
4.0	X Type	15°	SLV1ANA43415XM
	Y Type	15°	SLV1ANA43415YM
	X Type	25°	SLV1ANA43425XM
	Y Type	25°	SLV1ANA43425YM

# ANGLED ABUTMENTS

# DIMENSIONS

## Standard Angled Abutment

4.5 - 5.0

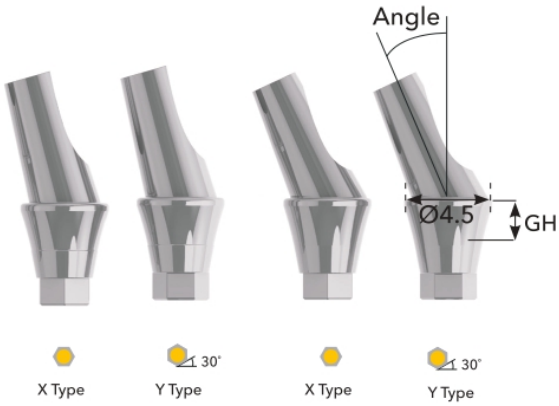

GH	Type	Angle	Ø4.5
2.0	X Type	15°	SLV1ANA45215XS
	Y Type	15°	SLV1ANA45215YS
	X Type	25°	SLV1ANA45225XS
	Y Type	25°	SLV1ANA45225YS

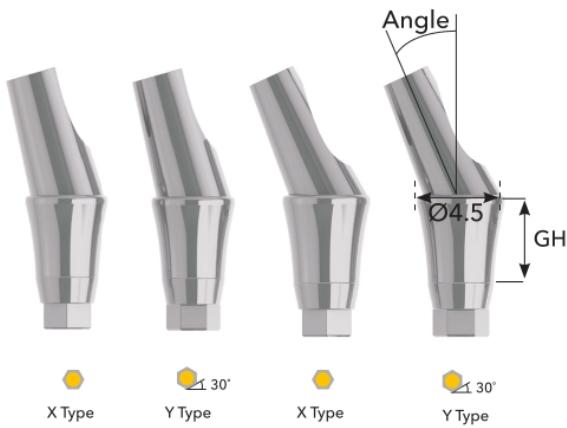

GH	Type	Angle	Ø4.5
4.0	X Type	15°	SLV1ANA45415XS
	Y Type	15°	SLV1ANA45415YS
	X Type	25°	SLV1ANA45425XS
	Y Type	25°	SLV1ANA45425YS

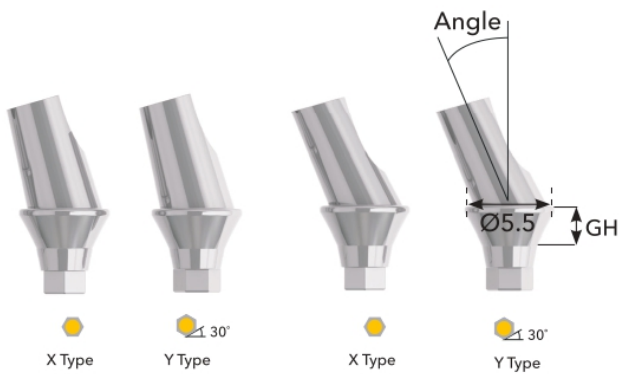

GH	Type	Angle	Ø5.5
2.0	X Type	15°	SLV1ANA55215XS
	Y Type	15°	SLV1ANA55215YS
	X Type	25°	SLV1ANA55225XS
	Y Type	25°	SLV 1ANA55225YS

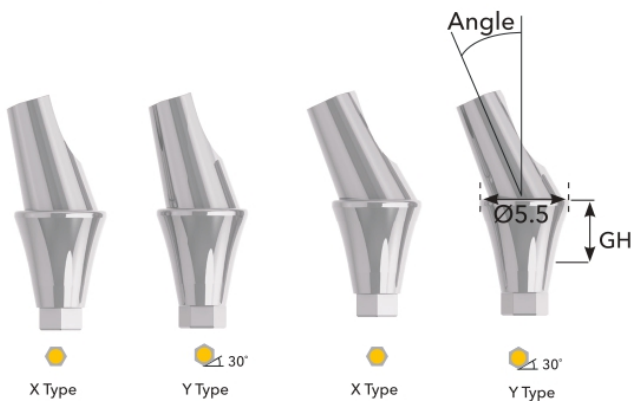

GH	Type	Angle	Ø5.5
4.0	X Type	15°	DTI1ANA55415XS
	Y Type	15°	DTI1ANA55415YS
	X Type	25°	DTI1ANA55425XS
	Y Type	25°	DTI1ANA55425YS

# DIMENSIONS EQUATOR ABUTMENTS

∅  
3.5

## Mini Equator Abutment



Mini	
GH	∅3.5
1.0	SLV1EQA351M
2.0	SLV1EQA352M
3.0	SLV1EQA353M
4.0	SLV1EQA354M
5.0	SLV1EQA355M

∅  
3.8

## Standard Equator Abutment



Standard	
GH	∅3.8
1.0	SLV1EQA381S
2.0	SLV1EQA382S
3.0	SLV1EQA383S
4.0	SLV1EQA384S
5.0	SLV1EQA385S

## Equator-Ball Abutment Accessories



Equator
Lab
Extra Soft
Soft
Standard
Hard

Ball Attachments	
Normal	SLV1BACAPN
Hard	SLV1BACAPH

# BALL ATTACHMENT

# DIMENSIONS

## Ultra Mini Ball Attachment

3.0



Ultra Mini	
GH	Ø3.0
1.0	SLV2BAS301UM
2.0	SLV2BAS302UM
3.0	SLV2BAS303UM
4.0	SLV2BAS304UM
5.0	SLV2BAS305UM

## Mini Ball Attachment

3.5



Mini	
GH	Ø3.5
1.0	SLV1BAS351M
2.0	SLV1BAS352M
3.0	SLV1BAS353M
4.0	SLV1BAS354M
5.0	SLV1BAS355M

## Standard Ball Attachment

3.5

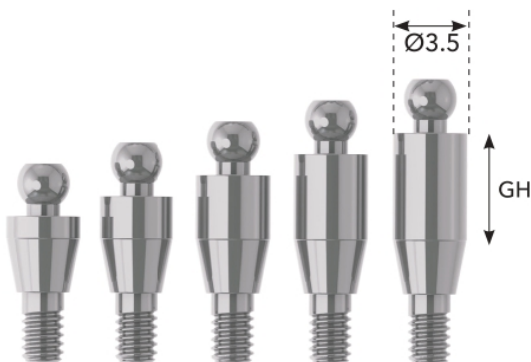

Standard	
GH	Ø3.5
1.0	SLV1BAS351S
2.0	SLV1BAS352S
3.0	SLV1BAS353S
4.0	SLV1BAS354S
5.0	SLV1BAS355S

Ultra Mini Threaded Abutment

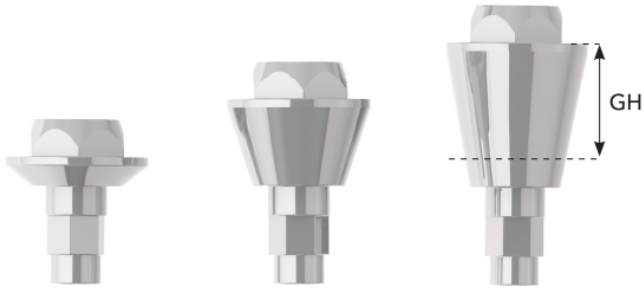

GH	Ultra Mini
1.0	SLV1VA1UM
3.0	SLV1VA3UM
5.0	SLV1VA5UM

Mini Threaded Abutment



GH	Mini
1.0	SLV1VA1M
3.0	SLV1VA3M
5.0	SLV1VA5M

Standard Threaded Abutment

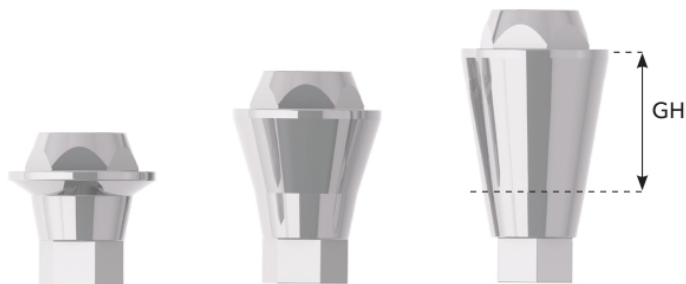

GH	Standard
1.0	SLV1VA1S
3.0	SLV1VA3S
5.0	SLV1VA5S

# MULTI UNIT STRAIGHT ABUTMENT

# DIMENSIONS

## Mini Multi Unit Straight Abutment



GH	Mini
1.0	SLV1MUSA1M
3.0	SLV1MUSA3M
5.0	SLV1MUSA5M

## Standard Multi Unit Straight Abutment



GH	Mini
1.0	SLV1MUSA1S
3.0	SLV1MUSA3S
5.0	SLV1MUSA5S

## Ucla Abutment

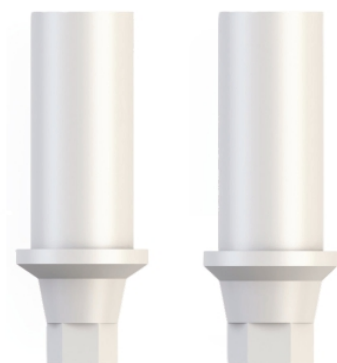

	H	GH	Ø4.5
Mini	7.0	1.0	SLV1UCLAM
Standart	7.0	1.0	SLV1UCLAS

Mini Multi Unit Angled Abutment

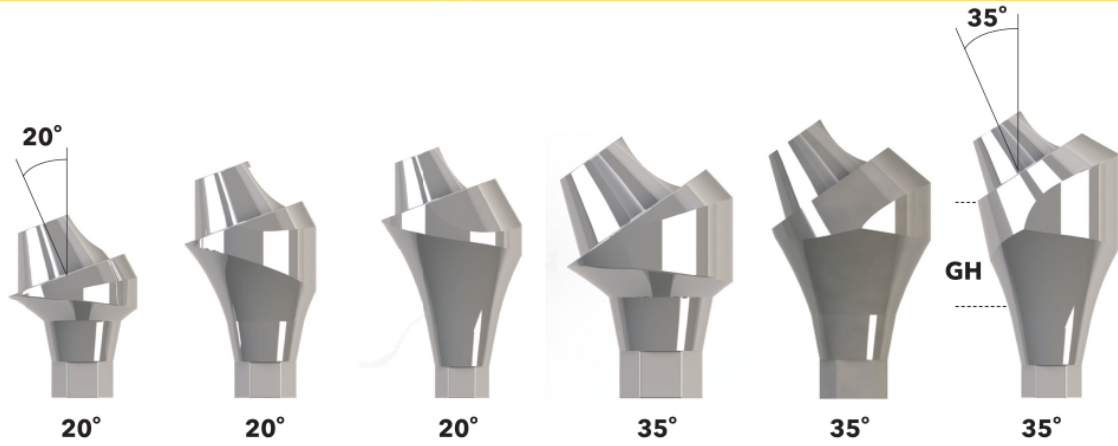

GH	20°	35°
1.0	SLV1MUANA201M	SLV1MUANA351M
3.0	SLV1MUANA203M	SLV1MUANA353M
5.0	SLV1MUANA205M	SLV1MUANA355M

Standard Multi Unit Angled Abutment

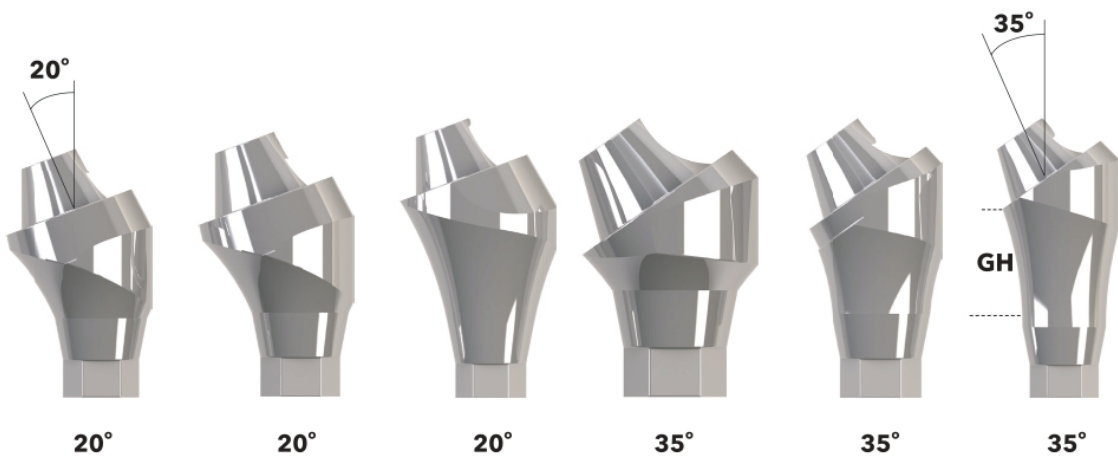

GH	20°	35°
1.0	SLV1MUANA201S	SLV1MUANA351S
3.0	SLV1MUANA203S	SLV1MUANA353S
5.0	SLV1MUANA205S	SLV1MUANA355S



# MULTI UNIT ABUTMENT

# DIMENSIONS

## Multi Unit Instruments



Plastic Coping	
<b>Non-Hex</b>	SLV1MUDA
<b>Hex</b>	SLV1MUDAH



Temporary	
<b>Non-Hex</b>	SLV1MUTA
<b>Hex</b>	SLV1MUTAH

## Multi Unit Instruments



Plastic Coping	
<b>Non-Hex</b>	SLV1MUDA
<b>Hex</b>	SLV1MUDAH



Temporary	
<b>Non-Hex</b>	SLV1MUTA
<b>Hex</b>	SLV1MUTAH

Open Tray Transfer

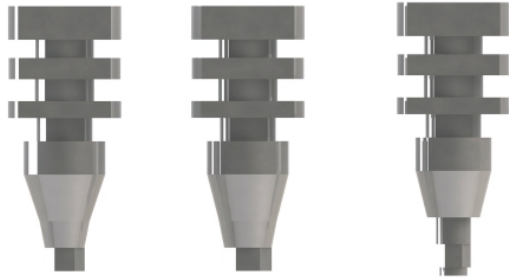

<b>Ultra Mini</b>	SLV1AKITIUM
<b>Mini</b>	SLV1AKITIM
<b>Standard</b>	SLV1AKITIS

Standard Implant Transfer Coping

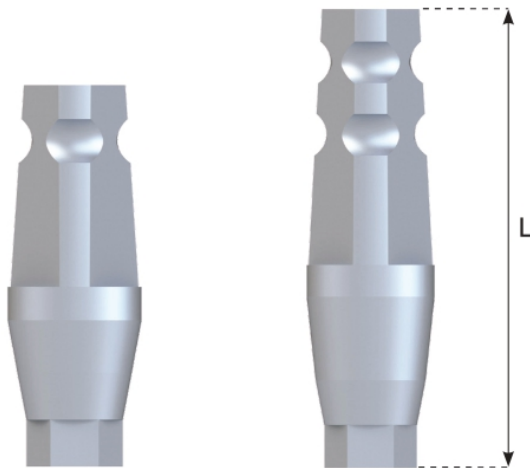

<b>L</b>	<b>Ø4.0</b>
<b>11</b>	SLV1ITI4011S
<b>14</b>	SLV1ITI4014S

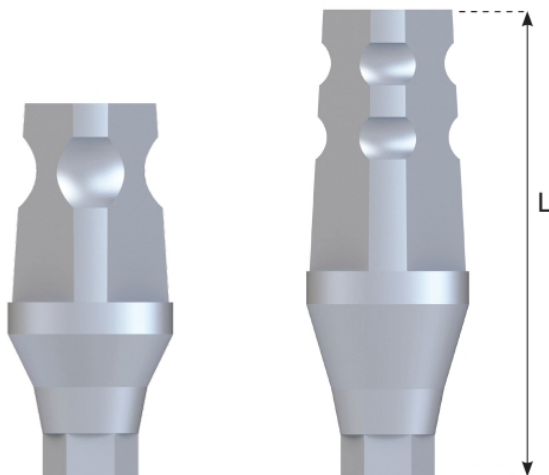

<b>L</b>	<b>Ø5.0</b>
<b>11</b>	SLV1ITI5011S
<b>14</b>	SLV1ITI5014S

# IMPLANT TRANSFER COPING

# DIMENSIONS

## Ultra Mini Implant Transfer Coping

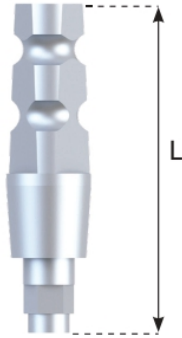

L	Ø3.0
11	SLV2ITI3011UM
14	SLV2ITI3014UM

## Mini Implant Transfer Coping

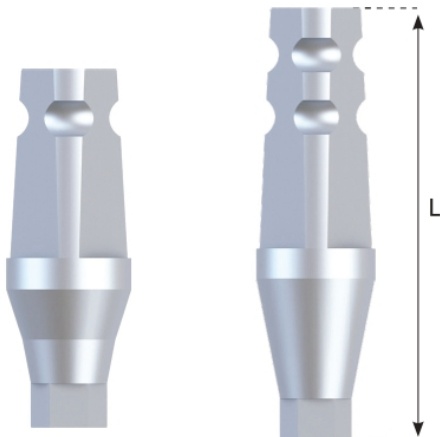

L	Ø4.0
11	SLV1ITI4011M
14	SLV1ITI4014M

DIMENSIONS

**ANALOG**

Analog



Ultra Mini

Mini

Standard

<b>Ultra Mini</b>	SLV2ILAUM
<b>Mini</b>	SLV1ILAM
<b>Standard</b>	SLV1ILAS

Implant Ball Analog



<b>Ultra Mini</b>	SLV2BLAUM
<b>Mini</b>	SLV1BLAM
<b>Standard</b>	SLV1BLAS

Implant Multi Analog

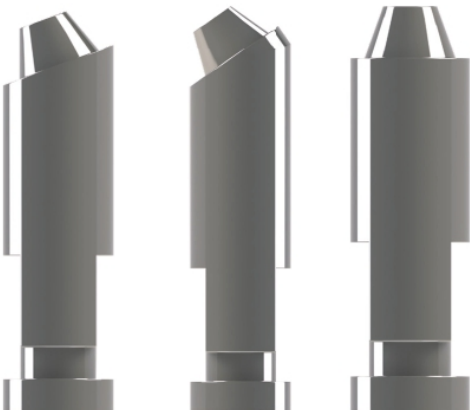

	<b>Straight</b>	<b>Angled-20°</b>	<b>Angled-35°</b>
<b>Non-Hex</b>	SLV1MUILAS	SLV1MUILAA20	SLV1MUILAA35
<b>Hex</b>	SLV1MUILASH	SLV1MUILAA20H	SLV1MUILAA35H

# SOLVO FLOW DIAGRAMS

## Ti-Base Abutment & Components

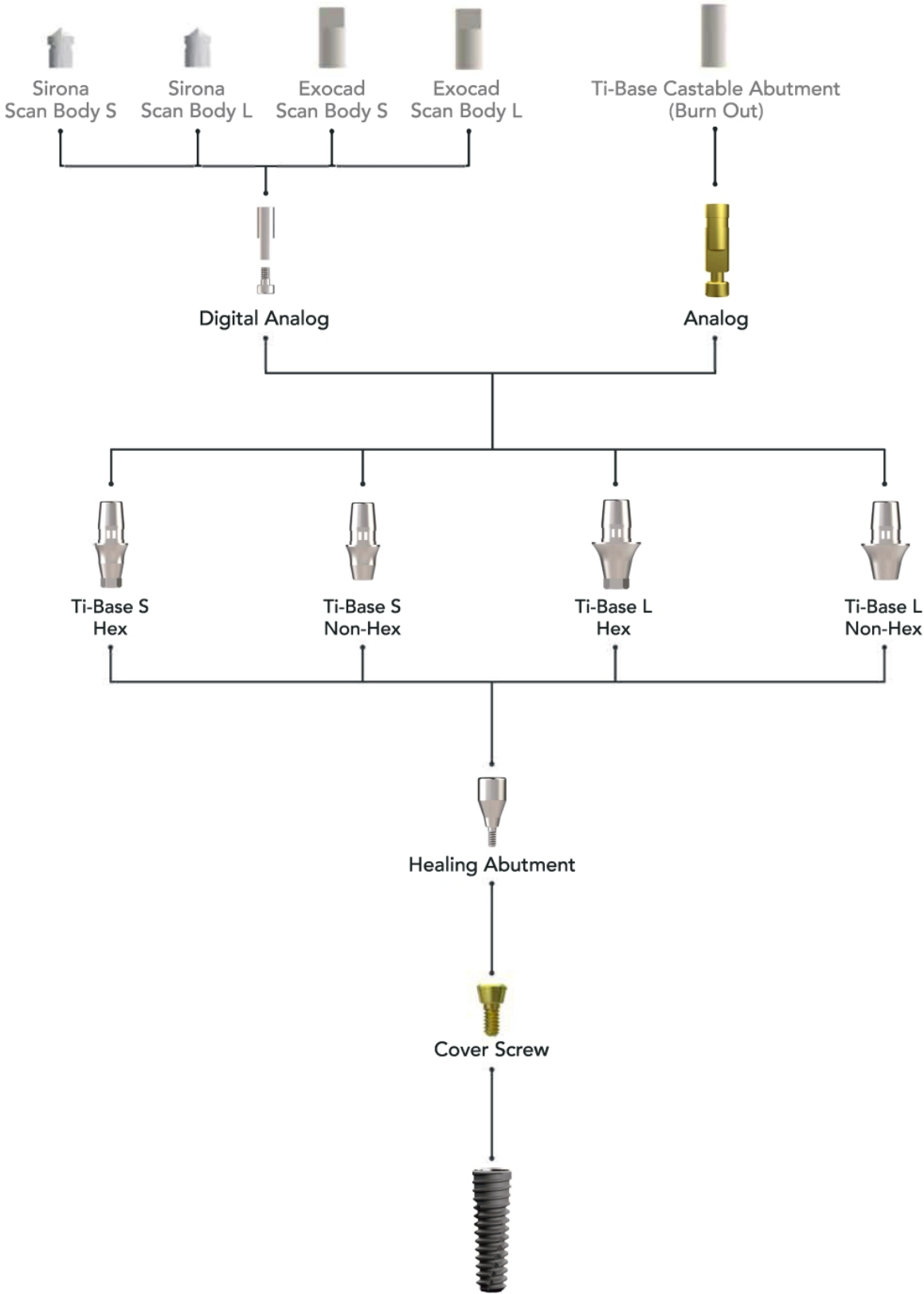

DIMENSIONS

SURGICAL KIT

# SURGICAL KIT

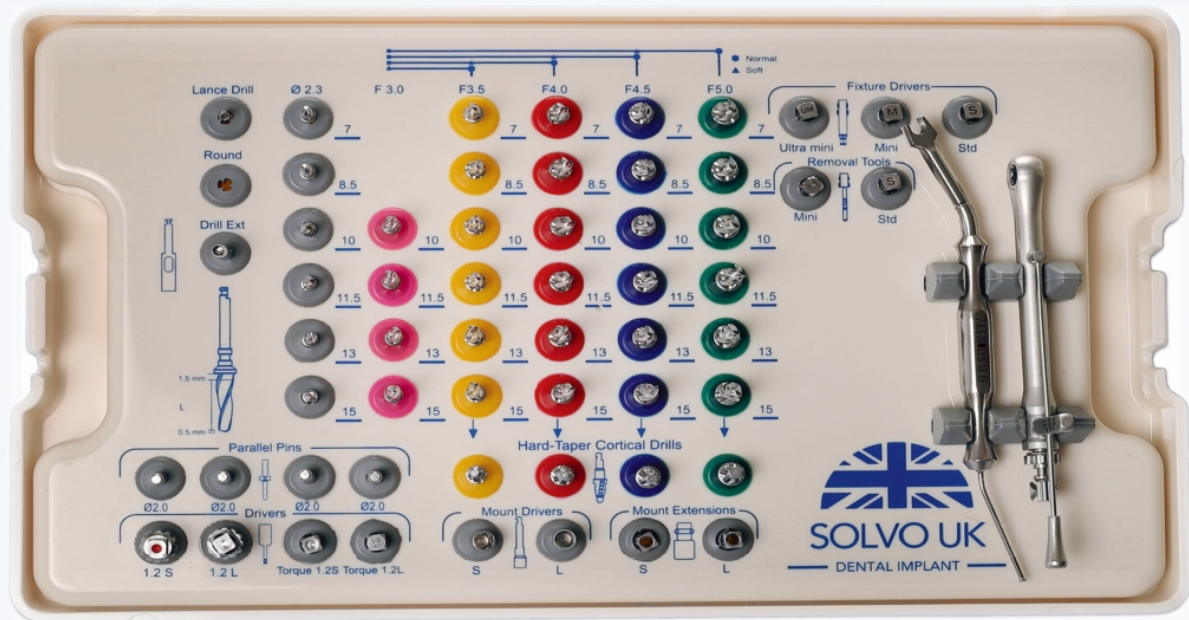

## SOLVO Exclusive Surgical Set Upgradable Up To 50 Stoppered Drills

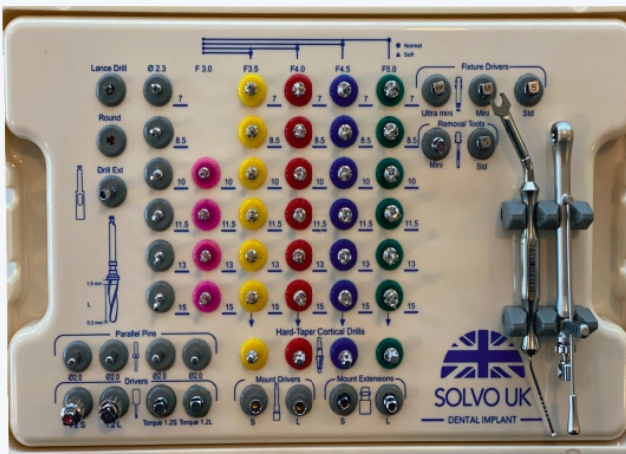

We have mastered the art of simplifying implant technology by developing a surgical kit that fits all our products and implants, abutments and surgical tools. Our surgical kit includes basic surgical instrumentation to advanced therapy tools and is compatible with all our implant systems.

SOLVO SURGICAL KIT DRILLS						
L	Ø2.2	Ø3.0	Ø3.5	Ø4.0	Ø4.5	Ø5.0
7	SLVF2270	----	SLVF3570	SLVF4070	SLVF4570	SLVF5070
8.5	SLVF2285	----	SLVF3585	SLVF4085	SLVF4585	SLVF5085
10	SLVF2210	----	SLVF3510	SLVF4010	SLVF4510	SLVF5010
11.5	SLVF2211	SLVF3011	SLVF3511	SLVF4011	SLVF4511	SLVF5011
13	SLVF2213	----	SLVF3513	SLVF4013	SLVF4513	SLVF5013
15	SLVF2215	SLVF3015	SLVF3515	SLVF4015	SLVF4515	SLVF5015

Lance Drill	SLVDLADR
Hard-Taper Cortical Drill Ø3.5	SLVFHT35
Hard-Taper Cortical Drill Ø4.0	SLVFHT40
Hard-Taper Cortical Drill Ø4.5	SLVFHT45
Hard-Taper Cortical Drill Ø5.0	SLVFHT50
Driver 1.2 S	SLVDR12S
DRIVER 1.2 L	SLVDR12L
DRIVER TORQUE 1.2 S	SLVDT12S
DRIVER TORQUE 1.2 L	SLVDT12L
REMOVAL TOOL MINI	SLVDRTOM
REMOVAL TOOL STANDARD	SLVDRTOS
Depth Gauge	SLVDEPTH
RATCHET	SLVRACHT

Drill EXTENSION	SLVDDREX
Mount EXTENSION S	SLVDMEXS
Mount EXTENSION L	SLVDMEXL
FIXTURE DRIVER MINI	SLVDFDRM
FIXTURE DRIVER STANDARD	SLVDFDRS
FIXTURE DRIVER ULTRA MINI	SLVDFDRU
PARALLEL PIN Ø4.0	SLVDPLP4
PARALLEL PIN Ø5.0	SLVDPLP5
Mount DRIVER S	SLVDMODS
Mount DRIVER L	SLVDMODL
MULTI UNIT TORQUE 2,5	SLV1MUDT25
THREADED ABUTMENT TORQUE 3,2	SLV1VADT32

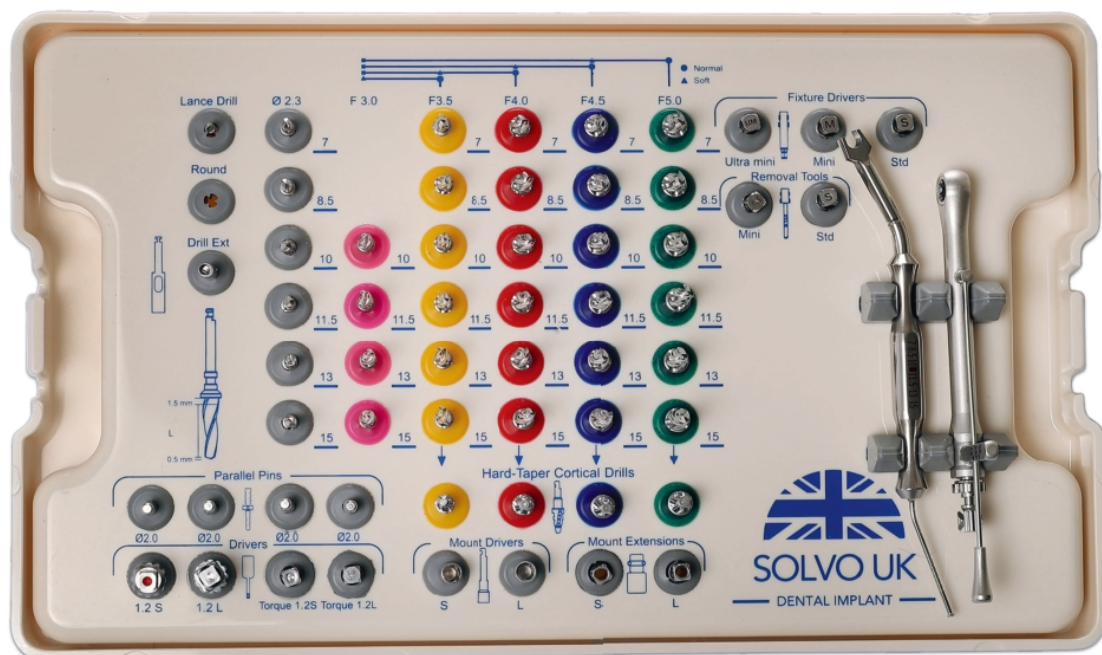

# WHY SOLVO UK IMPLANTS ?

SOLVO UK Implants is a British company which offers the dentists the best solutions of the highest quality in dental implants. We develop, manufacture and supply reliable premium implant systems.

SOLVO Implants provide and solve the complex problems of the dental implants for the patients and dentists simple and fast with a high standard service level.

## *Reliability and Quality*

SOLVO Implants conduct continuous and systematic quality control of all products which is confirmed by international quality standards ISO 13485, CE1984.

## *Lifetime Warranty and Identification*

SOLVO Implants provide lifetime warranty on all its products. All SOLVO Implants are assigned with a unique serial number that allows tracking the history of the product manufacturing from the first to the final stage.

## *Compactness and Availability*

We offer a simple and reliable solution for all possible clinical situations. The dentists use only one surgical kit to perform operations on all implant models.

*We leverage our experience and Technologies to ensure that our products offer the best value for Money.*

*Our mission is to make people smiling every day.*

**NEW DISTRIBUTORS, DEALERS AND CLINICS REQUESTS ARE WELCOME**

## **SOLVO UK IMPLANTS CO. LTD.**

**60 Millmead Business Center Mill Mead Road N17 9QU London / United Kingdom**

**7/24 Call Center: +44 7789 728035     [info@solvoimplants.com](mailto:info@solvoimplants.com)**

**[www.solvoimplants.com](http://www.solvoimplants.com)**

